

[45 SP] PM

[45 SP] PM

[it] [en]

SILVER

[it] [en]

SILVER

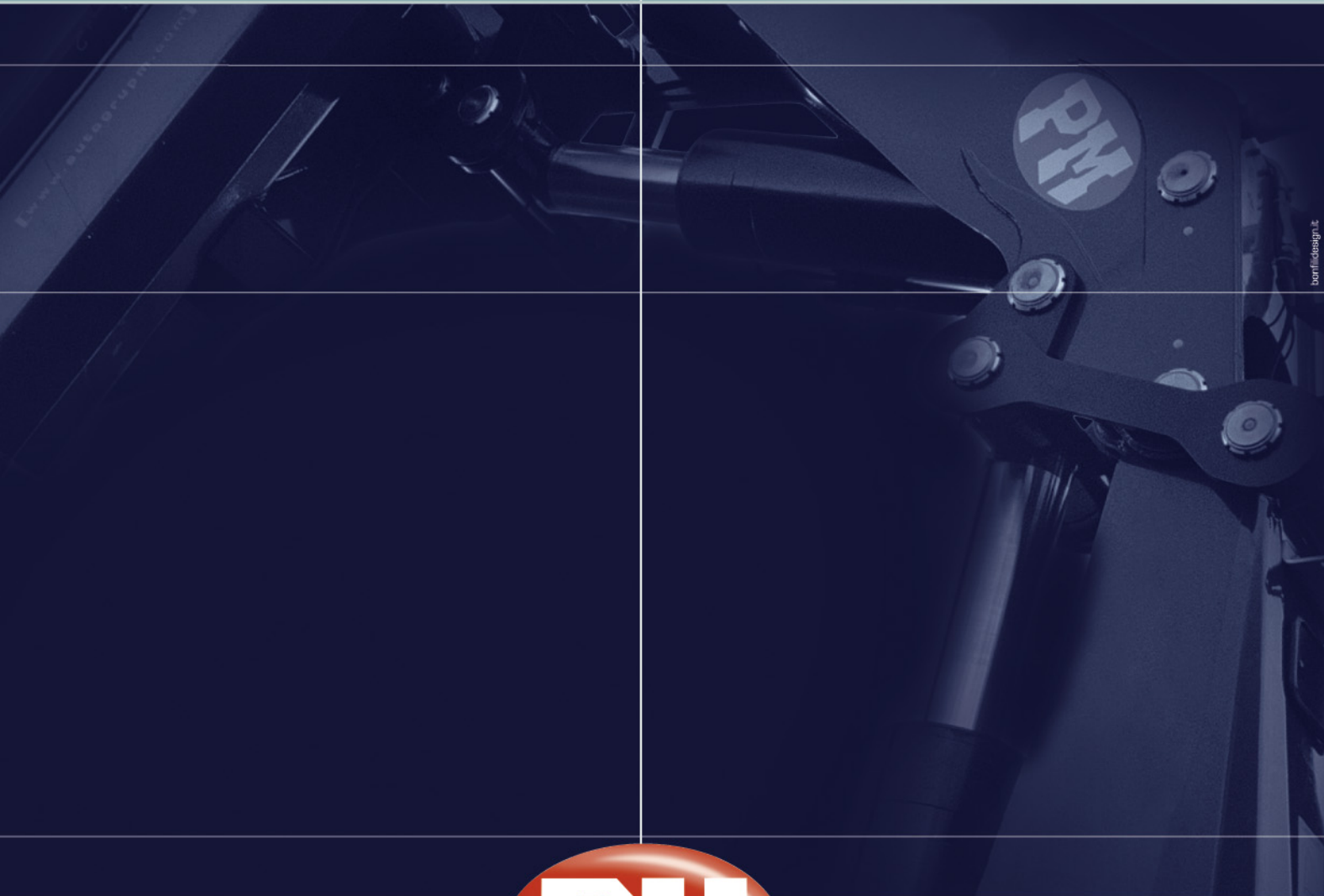

[elevate to the highest power] PM

Brought to you by:
American PM Crane Imports Inc.
Phone# (877) MY-PM-CRANE
(877) 697-6272
Or# (407) 246-1642
Dealer Inquiries Welcome:
Email: CorInq@PMCranes.Com

Conf. 834,896 ED. '07



[elevate to the highest power] PM

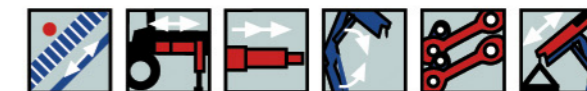

POTENTE ED AFFIDABILE PER OGNI IMPIEGO - POWERFUL AND RELIABLE FOR EVERY USE

Optional

- Radiocomando multifunzione di serie Scanreco/Hetronic.
- Scanreco/Hetronic multifunction radio remote control.



SISTEMA DI VERNICIATURA DI QUALITÀ CERTIFICATA
CERTIFIED PAINTING QUALITY SYSTEM



DICHIARAZIONE DI CONFORMITÀ DEL PRODUTTORE
DECLARATION OF CONFORMITY OF THE MANUFACTURER

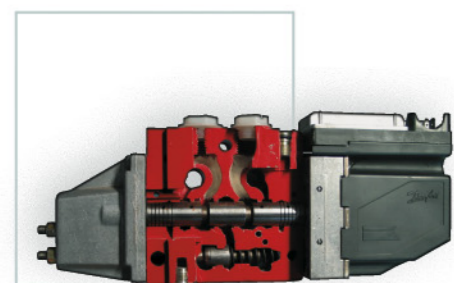

- Distributore proporzionale DANFOSS.
- DANFOSS proportional hydraulic control valve block.



- Scambiatore di calore
- Heat exchanger



- Verricello idraulico da 800 kg su antenna, fino a 1500 su gru.
- Hydraulic winches with a capacity ranging from 800 kg on jibs, up to 1500 kg on crane.



- Attivazioni alimentate con avvolgitubi
- Activations powered by means of hose winder.



3 ANNI DI GARANZIA SULLE PARTI STRUTTURALI
3 YEARS OF WARRANTY ON THE STRUCTURAL PARTS

- DOPPIE BIELLE SUGLI SNODI PER MOVIMENTI COSTANTI E DI PRECISIONE.
- DOUBLE CONNECTING RODS ON THE POINTS OF ARTICULATION TO ENSURE CONSTANT AND ACCURATE MOVEMENTS.

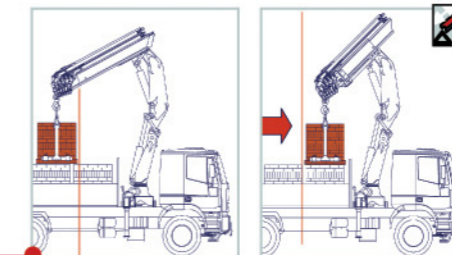

LC

- Gru PM, versione LC, con primo braccio retraibile idraulicamente, agevola le movimentazioni ingombranti e gravose a corto raggio, ottimizzando anche le posizioni di carico sotto colonna.
- PM crane in LC version, with first hydraulic retractable boom, optimizes the load positioning close to the column, and makes easy the placement of heavy and bulky loads.

- DISPONIBILE FINO A 8 ESTENSIONI IDRAULICHE con dispositivo di uscita sfilo sequenziale garantita per massima velocità e tutela dell'integrità del braccio stesso.
- UP TO 8 HYDRAULIC EXTENSIONS AVAILABLE with sequential extension exit device guaranteed for maximum speed and protection of integrity of the boom itself.



CONFORME ALLE NORME DI SICUREZZA EU
IN ACCORDANCE TO THE EU SAFETY STANDARDS

- Bracci stabilizzatori a sfilo idraulico
- Hydraulically extended outrigger booms



Cremagliera
Slewing by rack

Bracci stabilizzatori a sfilo idraulico
Hydraulic outrigger booms

Uscita sequenziale sfilo bracci
Extension sequence boom

Kit valvola di blocco rotazione
Slewing valve

Doppia biella
Double connecting rods

Configurazione LC
LC execution

45022 SP - 45022 SP LC

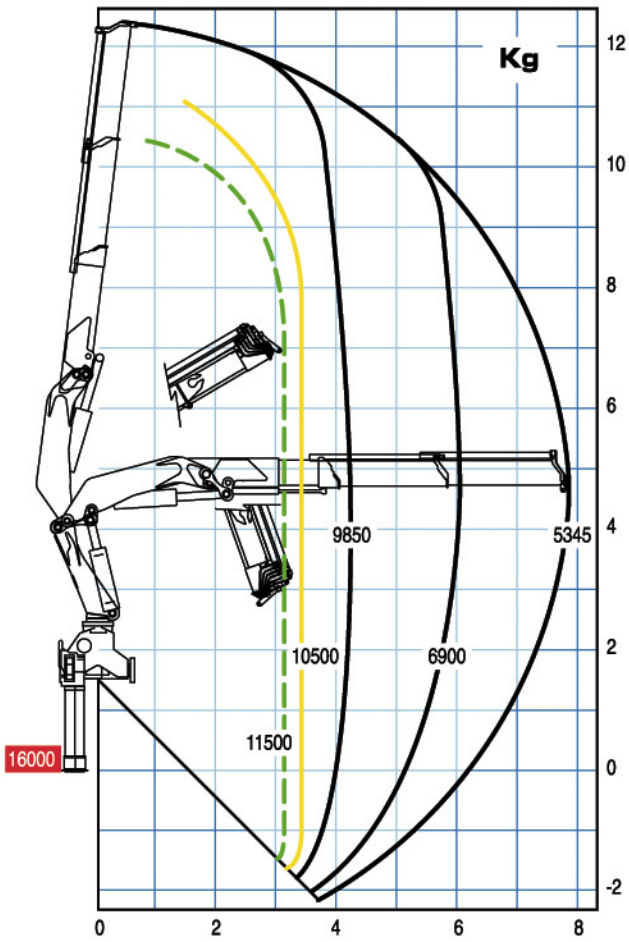

45023 SP - 45023 SP LC

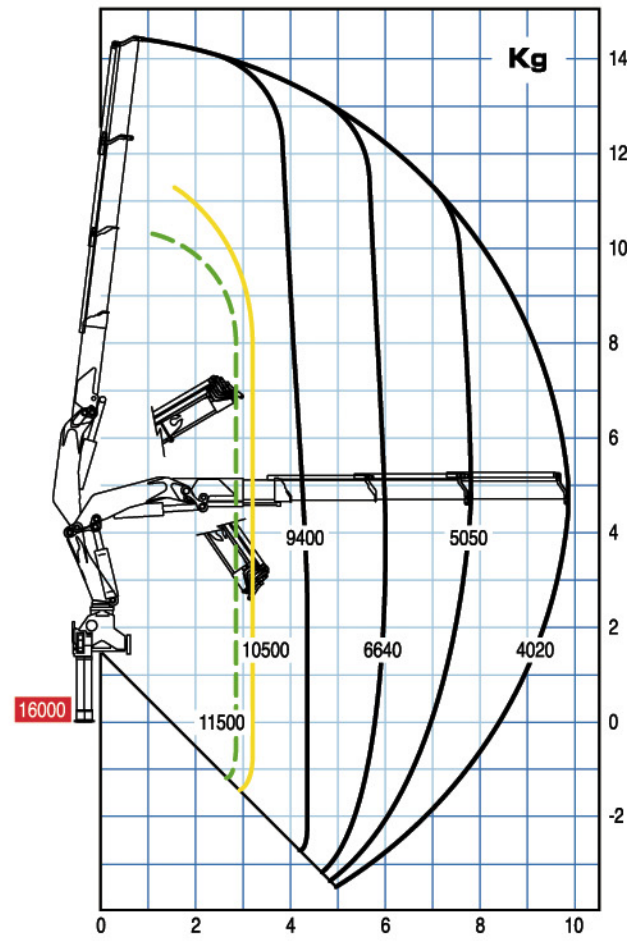

45026 SP - 45026 SP LC

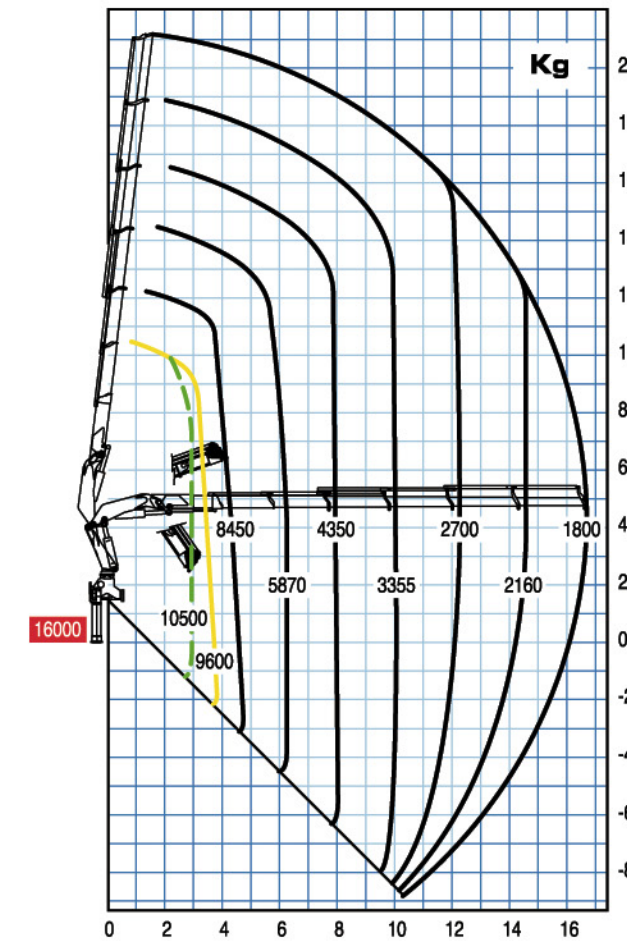

45027 SP - 45027 SP LC

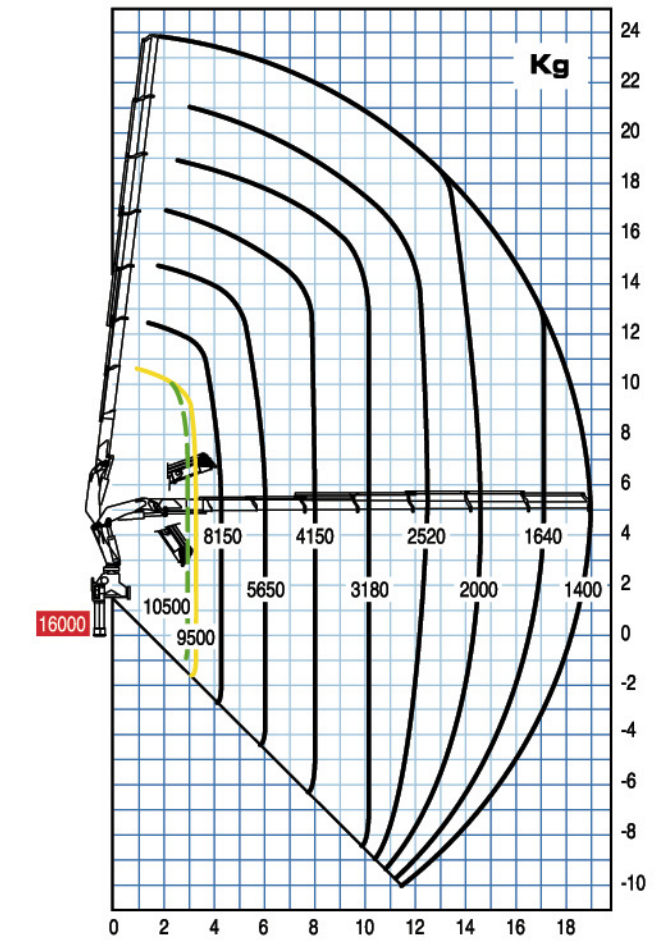

45024 SP - 45024 SP LC

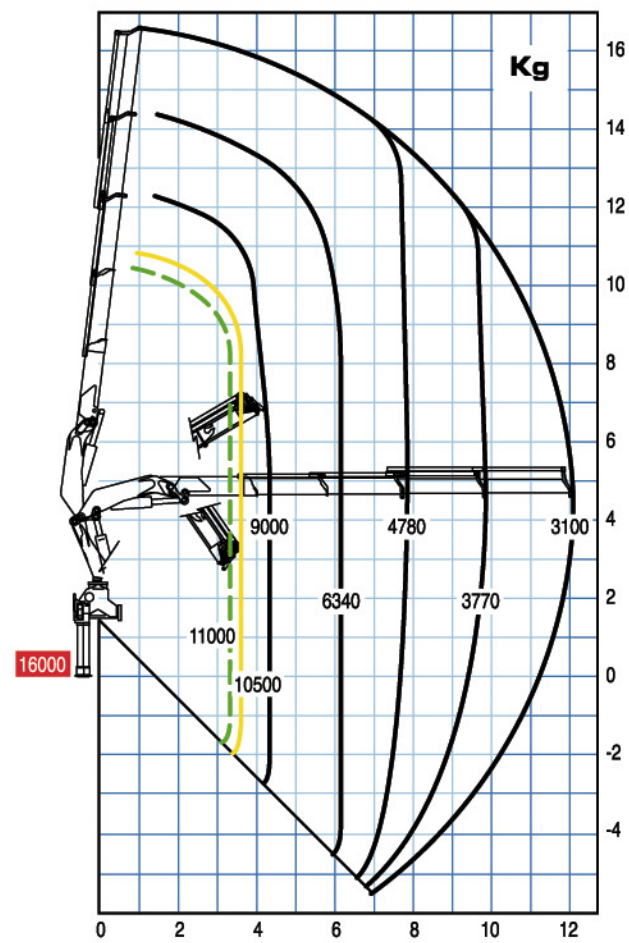

45025 SP - 45025 SP LC

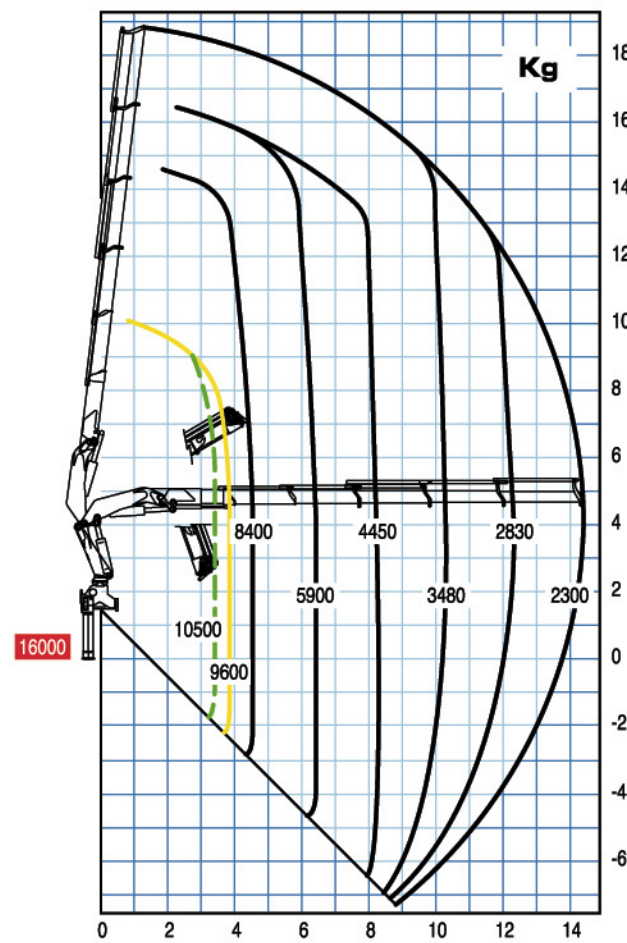

45028 SP - 45028 SP LC

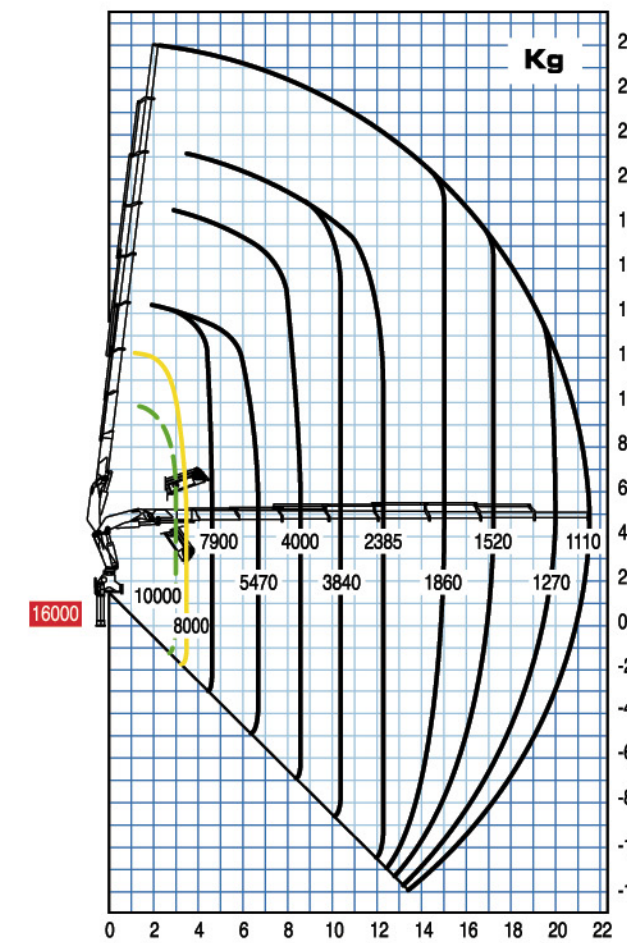

45024 SP + J903

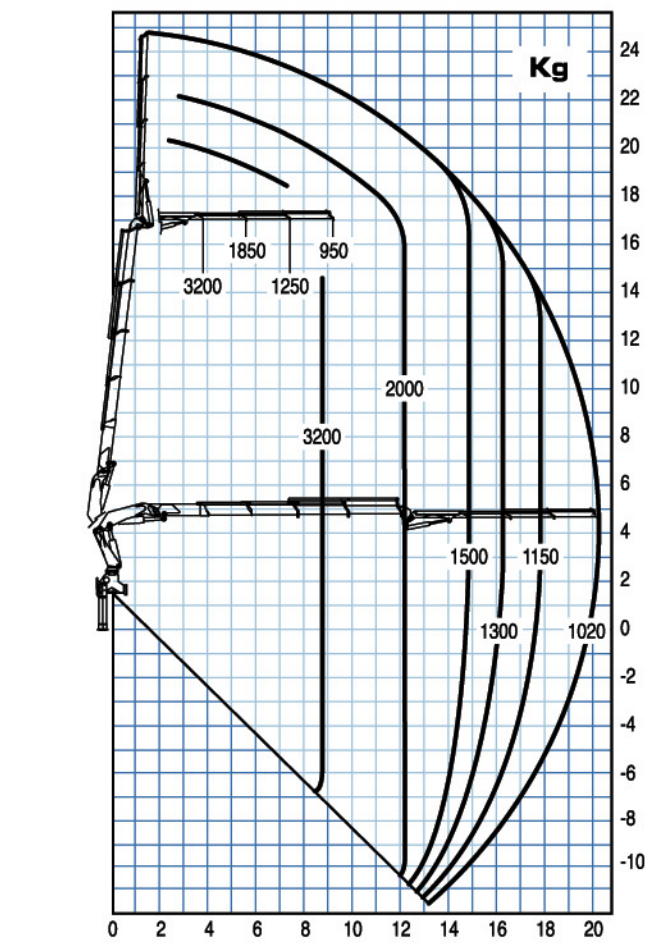

— Portata massima passante per l'orizzontale - Max. capacity from horizontal to vertical
 — Portata massima nominale al gancio fisso - Max. nominal capacity with fixed hook

— Solo con gru in versione LC
 — Only LC crane version

45024 SP + J904

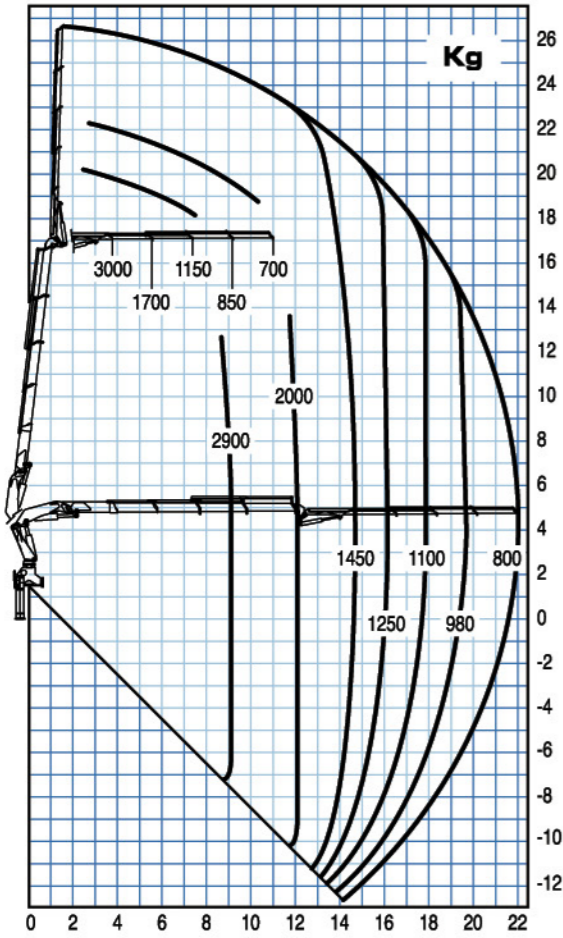

45025 SP + J903

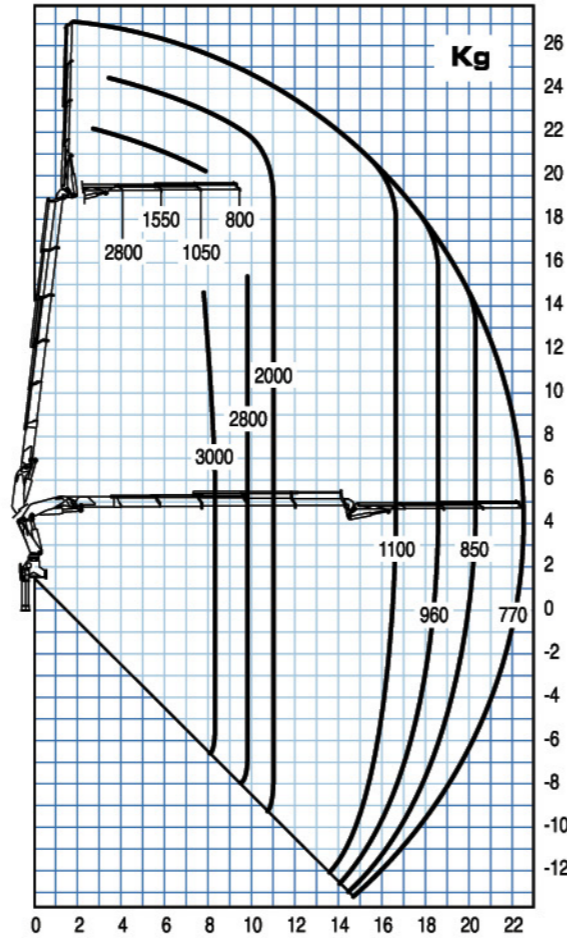

45025 SP + J904

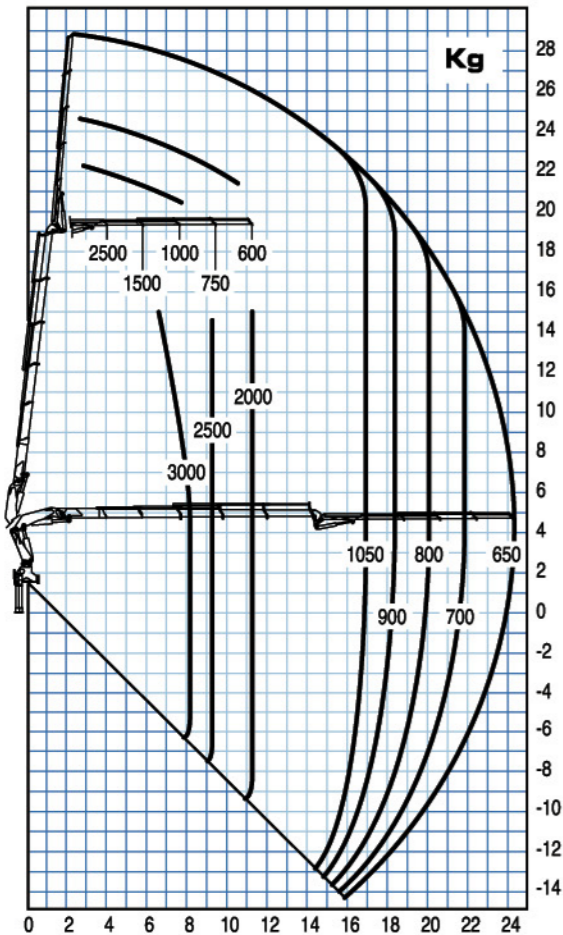

45026 SP + J703

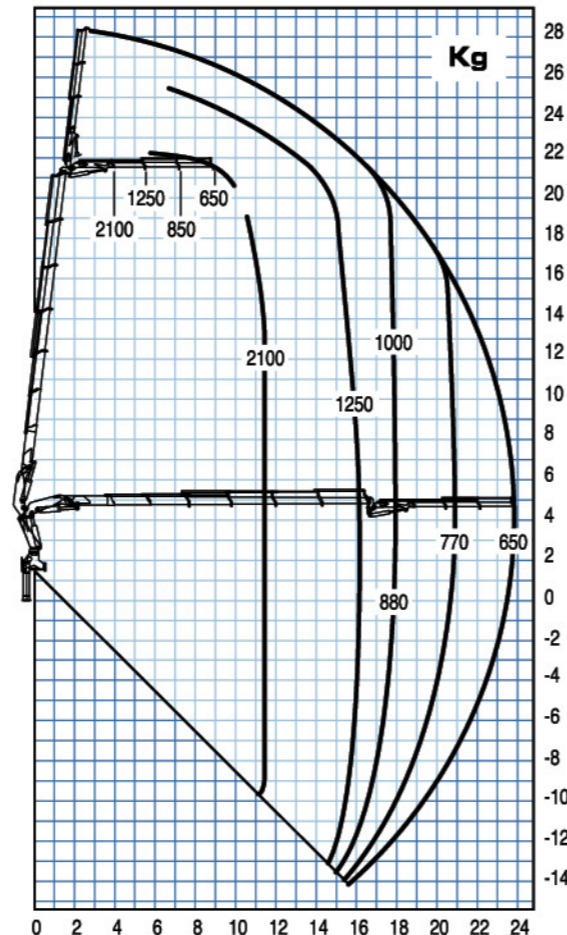

[45 SP] PM

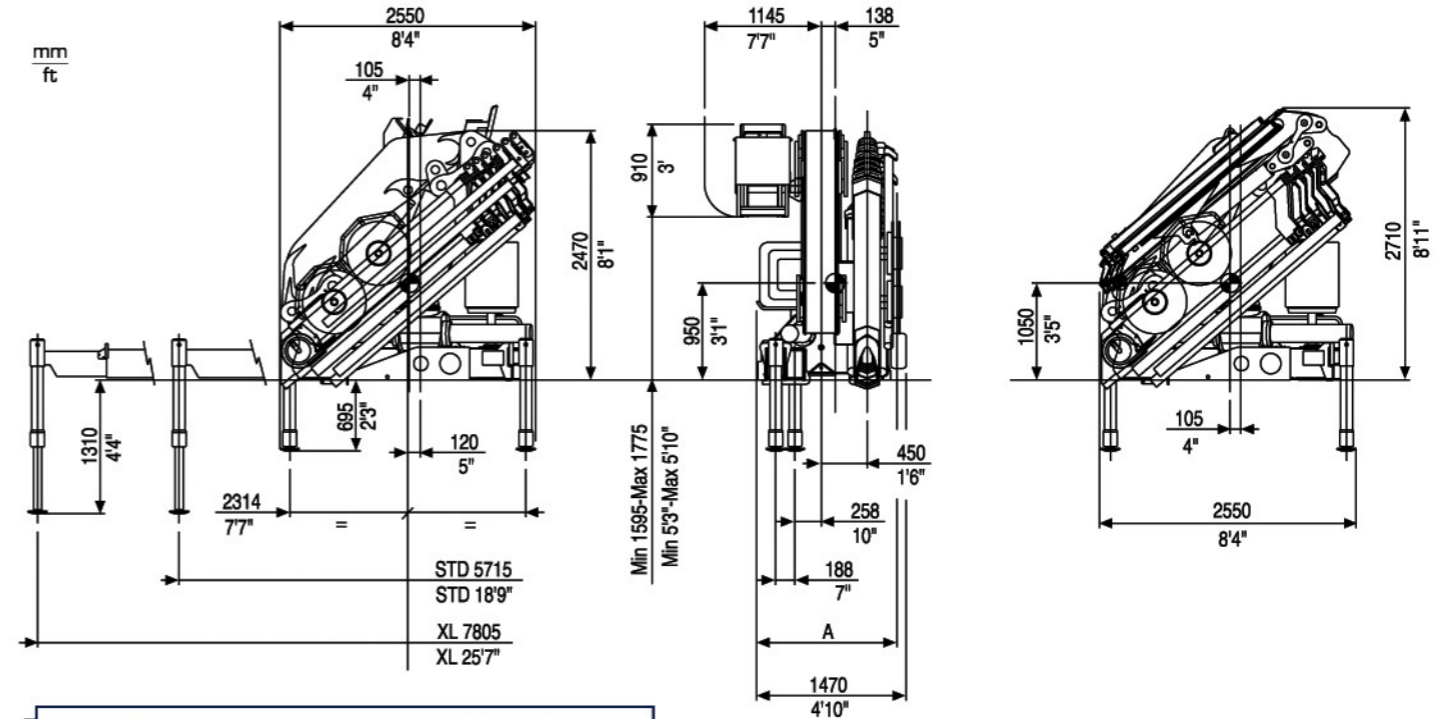

PTT/GVV 45SP **Abbinamento gru/veicolo**
Trucking crane combination

26,0 ton	 4 stabilizzatori 4 outriggers
32,0 ton	
44,0 ton	

PTT: Peso totale a terra - G.V.V.

	45022	45023	45024	45025	45026	45027	45028
A (m)	1320	1320	1320	1320	1420	1420	1420
A (ft)	4'4"	4'4"	4'4"	4'4"	4'8"	4'8"	4'8"

	45022	45023	45024	45025	45026	45027	45028	45024 +J903	45024 +J904	45025 +J903	45025 +J904	45026 +J703
Momento di sollevamento massimo Maximum lifting moment	kNm 404	386	380	379	369	364	360	-	-	-	-	-
	tn 41,2	39,4	38,7	38,6	37,6	37,1	36,7	-	-	-	-	-
Sbraccio oleodinamico Maximum hydraulic reach												
orizzontale - horizontal	m 7,80	9,90	12,10	14,60	16,65	19,10	21,45	20,20	22,00	22,45	24,25	24,25
verticale - vertical	m 11,45	13,55	15,70	18,00	20,20	22,50	24,90	23,95	25,75	26,20	27,95	27,95
Sbraccio con prolunghe Maximum reach with manual extensions												
orizzontale - horizontal	m 12,10	16,65	21,45	23,95	23,95	23,95	23,95	25,15	25,15	27,40	27,40	27,40
verticale - vertical	m 15,85	20,30	25,10	27,60	27,60	27,60	27,60	29,40	29,40	31,70	31,70	31,70
Impianto oleodinamico - Hydraulic system portata raccomandata - recommended oil flow	l/min 50	50	50	50	50	50	50	50	50	50	50	50
pressione massima - rated pressure	Mpa 31	31	31	31	31	31	31	31	31	31	31	31
capacità del serbatoio - tank capacity	l 200	200	200	200	200	200	200	200	200	200	200	200
Gruppo di rotazione - Slewing system angolo di rotazione - slewing angle	° 400	400	400	400	400	400	400	400	400	400	400	400
coppia di rotazione - slewing moment	kNm 40	40	40	40	40	40	40	40	40	40	40	40
pendenza massima di lavoro - max. working heel	%(°) 8,7(5)	8,7(5)	8,7(5)	8,7(5)	8,7(5)	8,7(5)	8,7(5)	0	0	0	0	0
Peso della gru standard - Standard crane weight Con serbatoio non rifornito - Empty oil tank	Kg 4355	4595	4840	5060	5260	5425	5570	5810	5890	6010	6080	6005
Versione LC - LC version Con serbatoio non rifornito - Empty oil tank	Kg 4510	4750	4995	5215	5415	5580	5725	5965	6045	6165	6245	6160

Tutte le gru PM sono coperte da polizza assicurativa internazionale per la responsabilità civile verso terzi
 All PM Cranes are covered by international insurance policy for civil liability third party
 I dati tecnici possono essere aggiornati senza preavviso - Technical data can be revised without prior notice

[45 SP][45 SP]^{LC}



45022 SP

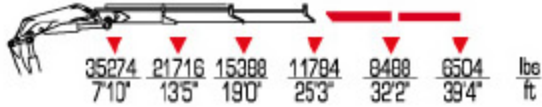

45023 SP



45024 SP



45025 SP

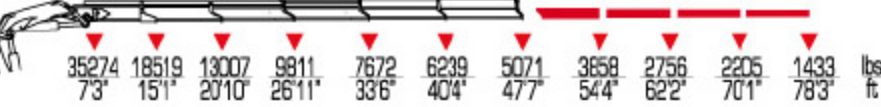

45026 SP

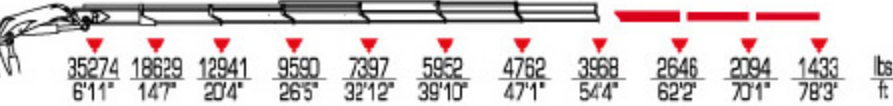

45027 SP

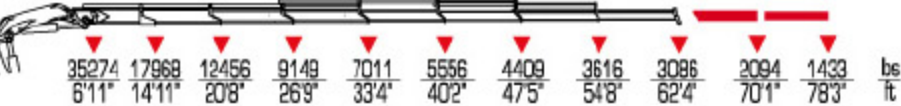

45028 SP



45024 SP + J903



45024 SP + J904



45025 SP + J903

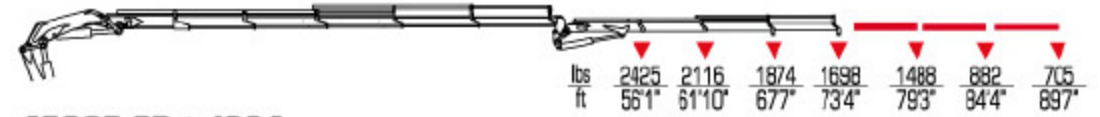

45025 SP + J904

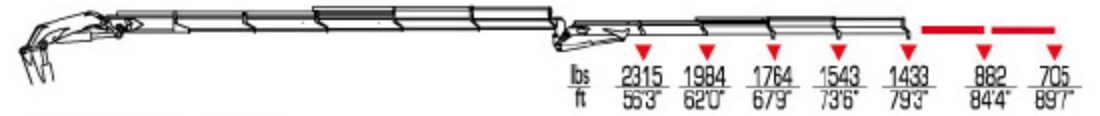

45026 SP + J703



	ft lbs	gals/min	Psi	400	lbs	ST	LC	8'4"	8'1"	44"	
45022 SP	298000	13	4500	400	9612	9943	8'4"	8'1"	44"	45022 SP	
45023 SP	284980	13	4500	400	10185	10516	8'4"	8'1"	44"	45023 SP	
45024 SP	279920	13	4500	400	10692	11023	8'4"	8'1"	44"	45024 SP	
45025 SP	279190	13	4500	400	11177	11508	8'4"	8'1"	44"	45025 SP	
45026 SP	271960	13	4500	400	11596	11927	8'4"	8'1"	44"	45026 SP	
45027 SP	268340	13	4500	400	11949	12280	8'4"	8'1"	44"	45027 SP	
45028 SP	265450	13	4500	400	12280	12610	8'4"	8'1"	44"	45028 SP	
45024 SP + J903	-	13	4500	400	12522	12853	8'4"	8'11"	48"	45024 SP + J903	
45024 SP + J904	-	13	4500	400	12699	13029	8'4"	8'11"	48"	45024 SP + J904	
45025 SP + J903	-	13	4500	400	13007	13338	8'4"	8'11"	48"	45025 SP + J903	
45025 SP + J904	-	13	4500	400	13184	13514	8'4"	8'11"	48"	45025 SP + J904	
45026 SP + J703	-	13	4500	400	12864	13195	8'4"	8'11"	48"	45026 SP + J703	